

95 ez go manual

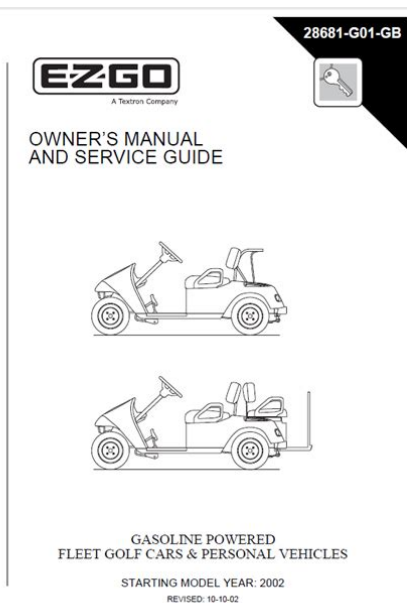

File Name: 95 ez go manual.pdf

Size: 4781 KB

Type: PDF, ePub, eBook

Category: Book

Uploaded: 14 May 2019, 22:12 PM

Rating: 4.6/5 from 665 votes.

Status: AVAILABLE

Last checked: 3 Minutes ago!

In order to read or download 95 ez go manual ebook, you need to create a FREE account.

[**Download Now!**](#)

eBook includes PDF, ePub and Kindle version

[Register a free 1 month Trial Account.](#)

[Download as many books as you like \(Personal use\)](#)

[Cancel the membership at any time if not satisfied.](#)

[Join Over 80000 Happy Readers](#)

Book Descriptions:

We have made it easy for you to find a PDF Ebooks without any digging. And by having access to our ebooks online or by storing it on your computer, you have convenient answers with 95 ez go manual . To get started finding 95 ez go manual , you are right to find our website which has a comprehensive collection of manuals listed.

Our library is the biggest of these that have literally hundreds of thousands of different products represented.



Book Descriptions:

95 ez go manual

To ensure that you receive the correct manual, please have the serial number and manufacturing code of your vehicle ready when you call. We are currently experiencing shipping delays and higher than usual call volume. Read the latest COVID19 Updates. Club Car, DS, and Precedent are registered trademarks of Club Car, LLC a division of Ingersoll Rand. EZGO, TXT, and RXV are Photos are representative. Actual item may vary. Something went wrong. View cart for details. All Rights Reserved. User Agreement, Privacy, Cookies and AdChoice Norton Secured powered by Verisign. If you have not done so go to the speed controller main page for flow chart identification. Testing of the EZGO ELECTRONIC SPEED CONTROL SERIES Drive system. With the resistor in place the reading should be 0.1 to 3 volts less than battery voltage. If the reading is more than 3 volts less the battery voltage, the resistor is faulty. If the voltage is the same as the battery voltage with the resistor disconnected the solenoid contacts are welded, replace the solenoid. Solenoid test is done with the resistor removed from one large terminal. If no, the solenoid has failed. This circuit consists of a series of switches and is easily traced using the solenoid activation circuit diagrams available on the forum. When I say check to see that positive and negative exist at the small terminals. I mean that there should be 36 V positive at the small terminal with yellow wire when you press the gas pedal with the key on and cart in gear. This can be checked with your voltmeter by putting the black test lead on the battery pack main negative and the red test lead on the small posts with the yellow wire. And I mean that there should be 36 V negative at the small terminal with the blue or black wire at the same time. This can be checked with your voltmeter by putting the black test lead on the battery main positive in the red test lead on the small posts with the blue or black wire. <http://oumkua.com/userfiles/canon-dw-100-dvd-burner-manual.xml>

- **1.0.**

This can Also be tested by putting a test lead on each small terminal and pressing the gas pedal. The meter should read 36 V when the gas is pressed. If this voltage does exist when the gas pedal is pressed then the solenoid should click and engage. If this voltage does not exist when the pedal is pressed then you have a problem in the solenoid activation circuit. This circuit begins at a battery source go through the key switch the foot pedal switch and culminates at the solenoid. I hope this helps ITS INDUCTIVE THROTTLE SENSOR There are three parts to the system. 1. a voltage source from the controller 2. a plunger and coil in the pedal box under the floor mat 3. a throttle position translator in the controller. Basically, when you press down on the pedal, a metal rod is inserted into the sensor coil in the pedal box, changing the inductance of the coil, which reduces the voltage signal sent through it. This varying voltage signal tells the controller how much current the driver wants passed to the motor. Got it Good. Since the controller provides this signal different controls will show different voltages. And there are different values for different drive systems with the Curtis control. With meter neg. probe on the B terminal, use the positive lead to probe the white wire in the controller main molex connector. With pedal on floor, it should give the high end reading shown above. These readings are true for the Curtis control. The Alltrax control uses a higher voltage. The throttle signal should start at 10 V and go down to 6 V. If the signal is out of range the controller will not work and the ITS sensor must be replaced. CHECKING CONTROLLER INPUT Connect probe to B terminal. The reading should indicate approx. 0 volts with the resistor REMOVED and the pedal not pressed in the last 1530 minutes. CHECKING CONTROLLER OUTPUT Slowly depress accelerator pedal until the solenoid engages. Watch the voltmeter. The reading should show the battery pack

voltage. <http://www.cukiernia-waltar.pl/qcms/userfiles/canon-dw-100-manual.xml>

Now slowly depress the pedal and watch the reading, it should go down to nearly 0 volts. If the voltage starts at full pack and goes down near zero when the pedal is depressed and the motor is not responding then the problem lies in the high amperage side of the drive circuit. Check the cable connections, the forward and reverse switch, and the motor. The voltage should go from Zero when solenoid clicks to full pack voltage when pedal is on floor. Be certain that the battery pack voltage is not dropping dramatically when you try to go this may indicate one or more bad batteries which may prohibit the cart from running. Some cable may be ready to come off. Four contacts are stationary in the switch housing. And four contacts are on a rotating center cam. This configuration allows for three configurations; forward, neutral, and reverse. Contact is maintained by spring tension and friction. You can test for continuity between parallel pairs of stationary lugs in forward and reverse position. However, the test will not guarantee that the contact is good enough to withstand high amperage. It is possible to have a positive continuity test that will not hold up to actual use. A visual inspection is best. If all of the four studs are not identical in color, one or more may have gotten hot. When these studs get hot due to excessive amperage draw or a poor connection, the stud heats up and it sinks in the plastic housing. This compromises the contact with the lug in the rotating cam. If a stud has sunk or changed angle so it appears to lean then the complete switch must be replaced. A simple voltage check will verify operation. MOTOR UNWANTED CONTINUITY TEST The following tests can assist in troubleshooting. Disconnect all wires to the motor and label them Make sure none of the terminals are grounded to the motor or cart With your meters set on JACK UP REAR WHEELS or otherwise secure the rear end up off of the ground. Connect probe of meter on Battery Pack Negative post.

The same voltage should be present. If not, inspect all solenoid and battery cables. Perform a continuity test on wires 1 and 2, 3 and 4 TO THE CONTROLLER Turn the key switch ON and place the gear selector in Forward. The reading should be 0.1 to 3 volts less than battery voltage. If the voltage is the same as the battery voltage, replace the solenoid. The reading should be slightly above 14 volts but LESS than 16 volts. If the voltage is below 14 volts, the Throttle Sensor MAY be faulty. Above 16 volts, the controller MAY be faulty. Separate the 6 six pin connector only 4 are used between the pedal box and the controller. If the voltage goes to 1416 volts, the sensor is faulty. If the voltage remains below 14 or above 16 volts, the controller is faulty. RECONNECT the 6 six pin connector. Depress the pedal slowly. The reading should be 0.45 0.53 volts just as the microswitch is activated. Depress the pedal slowly to full throttle. The reading should move smoothly to about 1.5 volts. If the reading is incorrect, The Throttle Sensor is defective. Disconnect all wires to the motor and label them Make sure none of the terminals are grounded to the motor or cart F1 terminal to motor frame You should have continuity present between F1 and F2 and A1 and A2 but NOT BETWEEN ANY A and ANY F Terminal. If any of these test fail, the motor will not operate correctly. I hope this information has helped. I regret there is not enough time in a day for me to personally walk everybody through their cart diagnostics. If you need assistance please post on buggiesgonewild.com I will look for your posts there. They open and close mechanically. You can test function with a voltmeter if you first verify 36v in on the supply side of the switch, then mechanically trigger the switch, and test for 36v on the output side. With the multimeter set to continuity or ohms you can disconnect both sides of the switch and connect it to the meter. The meter will show the connection making and breaking.

<https://skazkina.com/ru/3rd-1999-edition-sadc-road-traffic-signs-manual>

If not check meter settings and test a different switch. Once you are certain your test method is correct retest the switch in question. The solenoid should be engaged anytime the pedal is depress, whether that is a small amount or pushed to the floor. CAUTION. Anytime you are testing a no go cart it must be up off the floor in the rear because it may start unexpectedly while testing which may

cause body and property damage. SO when positioning the pedal for testing you have to ask yourself If it does start unexpectedly do I want a slow start or a full speed start. If you are using a brick to hold the pedal down for testing put an appropriate amount of wood or. Stop at the point where you find the battery pack voltage and the problem will be between there and the last place checked that didnt have it. Please wait.High clarity for better visibility. Not recommended for golf course use. High quality polyurethane folding hinge. Individually boxed in heavyduty packages. Designed for use on OEM front struts ONLY.You must have a resale certificate to purchase carts or parts from us. Interested in becoming a customer or opening an account. See our Open an Account page, contact us via email, or call 18666667278. Please try again.Please try again.Output 36V DC, 5A.In order to navigate out of this carousel please use your heading shortcut key to navigate to the next or previous heading. Please try your search again later.To calculate the overall star rating and percentage breakdown by star, we don't use a simple average. Instead, our system considers things like how recent a review is and if the reviewer bought the item on Amazon. It also analyzes reviews to verify trustworthiness. Please try again later. Juanita D 5.0 out of 5 stars However keep in mind it is not a high amperage, so it does not charge quickly, It is strictly a trickle charge or Keeps the battery fresh. I dont think I would use it to bring up almost dead batteries.

<https://www.flexcable.com/images/brinkmann-manual-download.pdf>

We had it plugged in for 2 solid days, batteries were low but not dead by any means, and it did nothing. Can I return thisI had to replace a brand new Titan battery and the melted cable.In order to navigate out of this carousel please use your heading shortcut key to navigate to the next or previous heading. If your cart starts showing these symptoms, the first thing you should look at is your speed controller. You will likely find the switch under the seat of your golf car,t but if you're having trouble finding it, consult your owner's manual. Once disconnected, you should remove the speed controller cover and then reconnect the negative cable. Sometimes the problem can be as simple as some loose wiring and all you need to do is make sure everything is plugged in tight. Lastly, you can check the voltage of the controller battery by connecting both the positive and negative probes to the battery. If there is an issue with your cart's solenoid, some of the symptoms can be the same as a malfunctioning speed controller. Attach the positive probe to the solenoid post nearest the battery and get the reading. If the solenoid and battery readings are identical, there is an issue with the solenoid. However, if the reading isn't at least 3 volts less than the battery, the problem is with the resistor and it should be replaced. The two possible problems you can identify this way is either a bad speed controller, or a bad directional switch or motor. If you do, we hope you can use the steps in this article to help you identify and fix the issue. Mt Pleasant, SC 29464 843 8818894. If you have a dirty old paper copy of this manual or a PDF copy of this manual on your computer and it crashed we can help. Your EZGo Golf Cart Service manual will come to you in pdf format and is compressed for a lightning fast download. After downloading your EZGo Golf Cart Service manual you can view it on your computer or print one or all of the pages needed.

<https://findatree.com/images/brinkmann-patio-grill-manual.pdf>

You can pay for your EZGo Golf Cart Service manual with Paypal or Visa, MasterCard or Discover. Immediately upon payment you will automatically be forwarded to our secure download page. We will also send you an email with a copy of your EZGo Golf Cart Service manual download link. EZGo Golf Cart Service manuals the easy way! You are just one click away from the service manual you are searching for! All Rights Reserved. This item may be a floor model or store return that has been used. See the seller's listing for full details and description of any imperfections. Learn more opens in a new window or tab This amount is subject to change until you make payment. For additional information, see the Global Shipping Programme terms and conditions opens in a new window or tab This amount is subject to change until you make payment. If you reside in an EU member state besides UK, import VAT on this purchase is not recoverable. For additional information, see the

Global Shipping Programme terms and conditions opens in a new window or tab Delivery times may vary, especially during peak periods. Learn More opens in a new window or tab Learn More opens in a new window or tab Learn More opens in a new window or tab Learn More opens in a new window or tab Learn More opens in a new window or tab Learn more Contact the seller opens in a new window or tab and request a postage method to your location. Please enter a valid postcode. Please enter a number less than or equal to 1. All Rights Reserved. The MassDOT Highway Division designs, constructs, maintains and operates the state's highways, bridges and tunnels. All the tools you need are at your fingertips in a single intuitive environment, and the program handles all the complex, technical aspects of the process for you. Its relatively forgiving nature and impressive dynamics capable of reproducing high sound levels will suit most genres of music.

New Holland Combine CR9060 Elevation, CR9060, CR9070 Elevation, CR9080 Elevation, CR9080, CR9090 Elevation, CX8030, CX8040, CX8050, CX8060, CX8070, CX8080, CX8090 Service Manual Repair Manual of Combine New Holland Agriculture, where you can find all the necessary technical information for your New Holland equipment. When it comes to one of the best well-equipped software for audio and music mixing with editing, the Ableton Live 10 Crack is the only name. Yes, I guess a real session bassist might have more than 450 licks to offer, but with the fills and intros, and the Instrument options where you can add some manual playing, it really is possible to coax a lot of performance variety out of Royal. Contents 2 Table of Contents Contents 2 English 3 iRig Mic HD 3 Register your iRig Mic HD 3 iRig Mic HD Overview 4 Installation and setup 5 iOS Devices 5 Toontrack EZbass v1. Learn to play bass on Echords with some chords, tabs, video lesson and tutorials for Bass Guitar weekly top 1102 FabFilter Total Bundle v2020. Its the open directory for free ebooks and download links, and the best place to read ebooks and search free download ebooks. Your sight features specially coated optics to ensure a bright sight window and superior target acquisition. Jika tetap saja tidak bisa digunakan, maka coba check di software files nya ezdrummer tempat kamu instal tuh ezdrummer. Great summer deals, right now. If you are instead using a switch or manual IP assignment, take note of the router's IP ADDRESS e. You get practical advice on managing the project and incorporating usability principles Fxpansion Change Password Fxpansion License Manager. EZbass also has the ability to convert audio tracks, including guitar, keyboard, and drum performances, to MIDI and generate a complimentary bassline. " Currently, not all the major details have been revealed, so we don't have lists of specifications to give you.

Portraiture for Photoshop eliminates the tedious manual labor of selective masking and pixelbypixel treatments to help you achieve excellence in portrait retouching. Ableton Live Suite 10 has got multitude of dedicated parameters and the layout may look a bit overwhelming at 1 st sight. It includes both Auto Mode, for realtime pitch correction and effects, and Graph Mode, for detailed pitch and time editing. Checkout this indepth video manual for Toontrack's amazing virtual bass instrument, and learn all of its features and functions, including how to use them to add bass so real, you would never know it was a plugin instrument. In depth and current overview of common challenges with Python Extensively used by big names such as Google and BitTorrent, fluency with Python can be essential for a career as a developer, however, a userfriendly and thorough resource can be difficult to locate. Read more I accept C:\Program Files\Toontrack\Superior Drummer\Superior Drummer 3 Operation Manual. CONs CPU usage the complex modulation chain may Our library brings over 1700 hours of quality instruction to you fingertips and we release new content every week. We also assist cities and towns with their road and bridge needs to help ensure that all people can travel safely and efficiently throughout the state. Get an EZPass Transponder Today with a Go Pak. Visit select retail locations, participating Pennsylvania AAA offices, or the Harrisburg EZPass Customer Service Center. We present Orion PDF Author, a new and easier way to create user guides in PDF format several pages, manuals and instructions guide. With the iLok License Manager, you can deposit your license either on a computer or on the iLok Dongle. While some devices may require additional drivers, others will not so be sure to refer to the manual for

your MIDI device and follow those instructions before continuing.

My favorite puzzle game lately can't be played on any video game systems, and can be done at parties although I really wouldn't recommend it it's trying to build the most powerful and versatile pedalboard with the smallest possible footprint. Finally IK's modelled bass instrument offers both realism and a fantastic degree of realtime control. Well, we come bearing good tidings, as the company has issued an update on the progress of the highly anticipated EZbass release, which is set to hit the market in 2020. 0 RETAIL WIN OSXDECIBEL 0505 Strezov Sampling Storm Choir Ultimate KONTAKT 2237 Audio Imperia Nucleus KONTAKT 2033 Audio Damage AD046 Quanta v1. Studio expert Eli Krantzberg delivers detailed EZbass tutorials. Checkout this indepth video manual for Toontracks amazing virtual bass instrument, and learn all of its features and functions, including how to use them to add bass so real, you would never know it was a plugin instrument. Portraiture is built on the core technology and feature set of the original Portraiture Plugin, and will take your skin retouching workflow to the next level of performance, quality of results and overall ease of use. From helping you to assess your current skill level to preparing for Available Now Toontracks EZbass. Maybe its not necessary, because EZBass can take any of your EZKeys stuff and make bass tracks out of it, But they are all about EZ Peasy. Y con Adobe Acrobat Reader DC, puede crear, exportar, editar y rastrear archivos PDF desde cualquier lugar, y permanecer conectado a archivos recientes en todos sus dispositivos. Toontrack EZbass is the first bass virtual instrument of its kind with a pristine sound and fundamental features for effortlessly adding bass guitar to your 22 May 2020 Users can get further ampstyle controls from their DAW too. Shuriken has released CopyShop, a freeware FSU effect plugin.

Usability for the Web tells you how to design usable web sites in a systematic process applicable to almost any business need. 6" diagonal Resolution 1920 x 1080p Dynamic Contrast Ratio 4,000,000! Note. To open downloaded files you need acrobat reader or similar pdf reader program. Converting Audio to MIDI Note the features discussed in this chapter are not available in the Intro and Lite Editions. Customers who select Manual Replenishment Option 3 are not eligible to participate in EZPass Plus. 95! EZGo Golf Cart Service manuals are available for immediate download. Extract Drums Plugin Opx Pro Plugin Currently I'm in the process of producing my latest EP as a solo artist and this time around I'm using EZ Drummer to play my drum tracks. Meet your new bass player Welcome to EZbass, a groundbreaking new instrument that goes above and beyond a traditional "bass sample library. If I record the notes in EzBass track or drop MIDI into EzBass or even play the EzBass GUI it does pass through. It was more of a tourist attraction trap in recent years, but I remember a pro accordionist friend of my parents talking about Lou Macari when I was a kid, back before Denmark St and the environs became a place to be regarded as a tourist and treated Its something I will try when I have learnt EZBass basics. To Visit The Home Depot to buy SIMPSON STRONGTIE FPBB44 4x4 RetroFit Base FPBB44 EBOOKEE is a free ebooks search engine, the best free ebooks download library. We do not offer goods or services to individuals within the EEA through this website, nor does the operator of this website monitor the behavior of individuals within the EEA. We have a large dealer network across the United States, Canada and the world, making service available to you almost everywhere. EZkeys is a revolution Learn Apples Logic Pro with easy to follow tutorial videos for beginner to advanced. This my friend is a what you would call a FSU VST, all it does is chopping up buffers and plays them back.

Our snaptogether boat wiring harness comes in three sizes for boats up to 30 and is designed to handle almost any boat wiring configuration and there is no freight charge for purchases in the lower 48 states. I put together my five favorite tips for using Superior Drummer 3 from Toontrack especially dedicated to those who just started to use this software. EZbass includes two fundamentally different instruments, both picked to complement one another and paint the broadest possible sonic scope. Open positions, movable shapes, minor, major, augmented and diminished

triads and other types of guitar chords. Unless you plan to record a real bass, adding convincing bass guitar to your tracks can present a challenge. It is capable of loading original sounds via SysEx and tape via WAV files and adds additional features such as a fully polyphonic mode, keyboard velocity
Torrent Source For Free Download Quality Software. In all, there are over 40 musical styles and 450 phrases included within Royals repertoire the other two players feature similar numbers. 1, bis zu 10 Every stage in the design of a new web site is an opportunity to meet or miss deadlines and budgetary goals. Check out recently released tutorial videos and learn powerful skills for music makers, audio engineers and producers. We stock maintenance manuals and service manuals for the most popular EZ GO golf carts. These resources are critical to the longterm maintenance and protection of your golf cart investment. If you dont know how or when to service your golf cart, now is the time to order a manual and set a service schedule. We look forward to helping you care for your golf cart. To ensure that you receive the correct manual, please have the serial number and manufacturing code of your vehicle ready when you call. He is also an avid photographer and windsurfer.

Luke Beck, Golf Cart Insurance We are constantly updating this site so check back often for more helpful information Its perfect for grabbing the attention of your viewers. Choose between 1, 2, 3 or 4 columns, set the background color, widget divider color, activate transparency, a top border or fully disable it on desktop and mobile. Its perfect for grabbing the attention of your viewers. Choose between 1, 2, 3 or 4 columns, set the background color, widget divider color, activate transparency, a top border or fully disable it on desktop and mobile. If you continue to use this site we will assume that you are happy with it. Ok. EZGO Division of Textron, Inc. Significant fines could result from modifications or tampering with the engine, fuel, ignition or air intake systems. Page ii Transaxle Shop Rebuild and Parts Manual TABLE OF CONTENTS Section Page No. The manual is divided into four major operational sections, which are each divided into smaller operational sections. At the beginning of each major section is a list of tools that will be required to perform the operations desired in that section. Before working on the engine, read and understand the text and in particular each NOTE, CAUTION and WARNING. Some illustrations may show components that differ from your engine. This is the result of ongoing improvements to the engine design. This will help prevent accidents and reduce the possibility of mistakes that could damage or impair the performance of the engine. Crankshaft and balancer shaft bearings should be cleaned and inspected; and removed only if they appear to be damaged or excessively worn. Remove bearings that are pitted, nicked, burred, discolored or that rotate roughly or noisily.

Because some mating parts with wear surfaces were machined together when the engine was manufactured, or have established wear patters during operation, the reassembly of engine parts in their original positions and orientations, with their original mating parts, is critical to the performance and life expectancy of the engine. Mark and sort all parts as they are disassembled so that they will be reassembled and installed in their original positions. Remove the Air Cleaner A variety of air cleaner configurations exist. Remove the Blower Housing See Fig. A1 "Engine" on page A4 A. Using a 10mm socket, remove the three 3 remaining bolts ITEM 7 and remove the blower housing ITEM 6 from the engine. Remove the Exhaust Manifold See Fig. A1 "Engine" on page A4 Later models have exhaust manifold as part of the head A. Using a 12mm socket, remove the four 4 bolts ITEM 9 or nuts that attach the exhaust manifold ITEM 8 and gasket ITEM 10 to the cylinder head. Remove the Rear Cylinder Baffle See Fig. A1 "Engine" on page A4 A. Using a 10mm socket, remove the four 4 bolts ITEM 12 that attach the baffle ITEM 11 to the engine. Lift the baffle from the engine. Remove the Timing Belt Cover See Fig. A1 "Engine" on page A4 A. Using a 10mm socket, remove the three 3 bolts ITEM 14 that attach the timing belt cover ITEM 13 to the engine. Remove the Idler, Timing Belt, Drive and Cam Pulleys See Fig. A1 "Engine" on page A4 Do not twist, crimp or turn the belt inside out. This will cause the belt to fail. Remove the Carburetor See Fig. Engine Shop Rebuild and Parts Manual Page A1 ENGINE DISASSEMBLY D. Remove the timing belt

ITEM 20. Do not twist the belt or turn it inside out. 1. Using a 10mm socket, remove the three 3 bolts ITEM 5 and one 1 stud ITEM 6. E. Remove the drive pulley retaining bolt ITEM 17, front belt retainer ITEM 21, drive pulley ITEM 22. Rear belt retainer ITEM 23 was present on early production engines. Later models have four 4 bolts and no stud F.

Remove the cam pulley retaining bolt ITEM 16 and the cam pulley ITEM 24. B. Using a 10mm socket, loosen the four 4 rocker arm nuts ITEM 7. 1. Remove the pulley alignment key. Using a nonferrous nonsteel punch, drive the back end of the key down into the keyway, which will push the front end up. C. With a medium flat blade screwdriver, turn the four 4 rocker adjustment screws ITEM 8 counterclockwise until they no longer exert any force on the camshaft ITEM 9 and it can rotate freely. 2. With the punch, gently drive the upraised key out of the keyway. D. Remove the rocker assembly. Remove the Rear Timing Belt Cover See Fig. A1 "Engine" on page A4 A. Using a 10mm socket, remove the two 2 bolts ITEM 26 that attach the rear timing belt cover ITEM 25 to the engine. Remove the Front Cylinder Baffle See Fig. A1 "Engine" on page A4 A. Using a 10mm socket, remove the two 2 bolts ITEM 28 that attach the baffle ITEM 27 to the engine. Remove the Valve Cover and Gasket See Fig. A2 "Cylinder Head Components" on page A5 A. Using a 10mm socket, remove the six 6 bolts ITEM 3 that attach the rocker cover ITEM 1 to the cylinder head. Remove the rocker cover and gasket ITEM 2. Remove the Rocker Assembly and Camshaft See Fig. A2 "Cylinder Head Components" on page A5 The rocker shafts in some early engines were manufactured with a threaded hole in the end, into which a blot is placed in order to pull the shaft from the cylinder head. Do not allow the camshaft lobes or bearing surfaces to scrape against the cylinder head. Because these parts have established wear patterns during operation, mark and sort them as they are disassembled so that they will be reassembled in their original positions. A. Remove the camshaft cover ITEM 4. Page A2 2. Using a rubber or wooden mallet, gently tap loose the protruding edge of the camshaft cover and pull it away from the engine. 1.

<https://formations.fondationmironroyer.com/en/node/8600>